

A : Rinsage - B : Nettoyage par impact

Pour les modèles de type "clip-on", le débit augmente d'environ 0,5m<sup>3</sup>/h.

## Dimensions (mm / pouces)

### Filetage

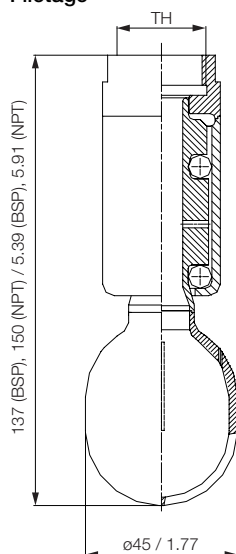

### TH

1/2" Rp (BSP)  
3/4" Rp (BSP)  
1/2" NPT  
3/4" NPT

### Clip-on

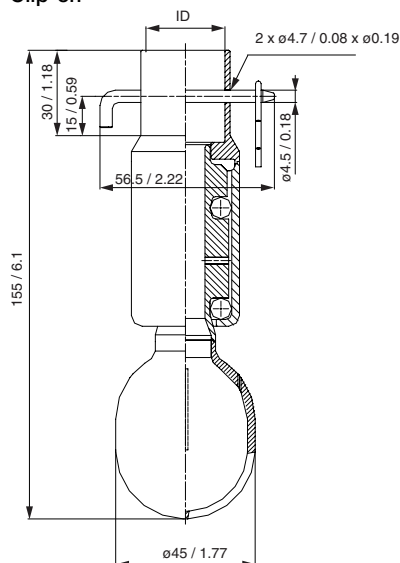

### DI

ISO : ø25,3 mm

### À souder

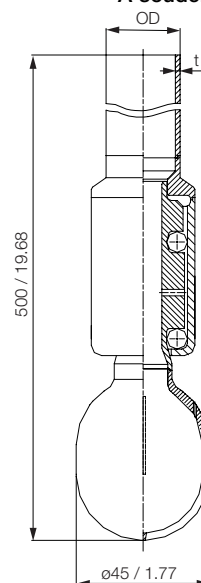

### DE x t

**Soudé sur la conduite**  
ISO : ø25 x 1,6 mm  
DN25 : ø29 x 1,5 mm

